

# Anschutz Trigger Adapter for Winchester Rifles

## Fitting Instructions:

The figures below show the items that are found in your adapter kit. It also includes two 5x32 torxs' screws and wrench which are not shown.



Figure 1: Roll Pin

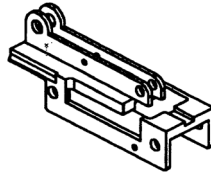


Figure 2: Adapter

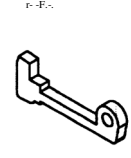


Figure 3: Sear Transfer Bar

## Step 1

Shorten your Anschutz trigger as shown in the before and after figures. This may be necessary to avoid interfering with the action screws of your rifle. Make your cuts level with the most extreme points of the lower part of the trigger housing. Make sure that all burrs and rough spots are removed from the top of the housing, especially if the trigger has been used before. This will ensure that the adapter fits flush with the top of the trigger housing.

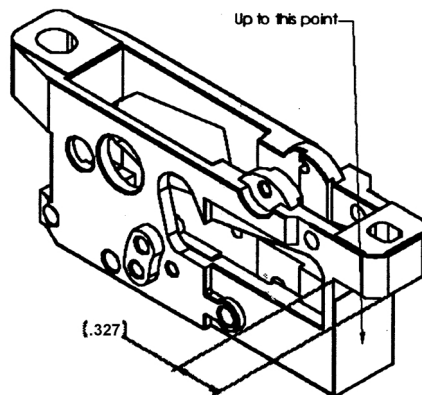
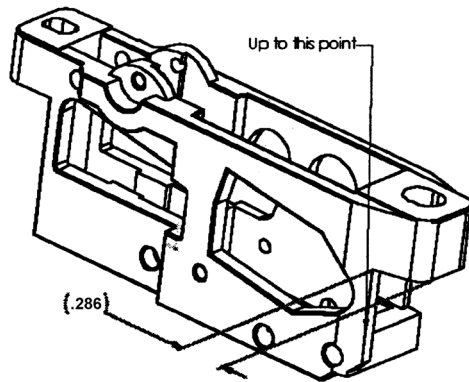
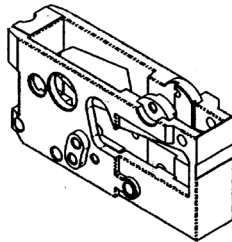


Figure 4: Rear Cut



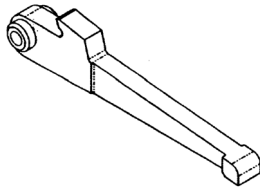
**Figure 5: Front Cut**



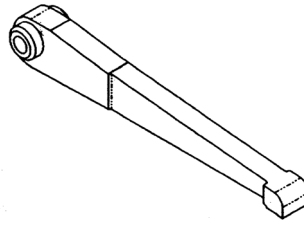
**Housing after being cut**

## Step 2

Carefully remove the Anschutz sear from the housing. Remove one e-clip and ease out the pin. Take great care when removing the return spring. Also, take note of the steps in your disassembly, especially where each part fits. Once you have removed the sear, modify the sear as shown in figures 11 and 12.



**Figure 6: Uncut Sear**



**Figure 7: Cut Sear**

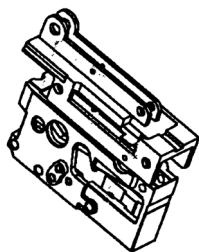
Now completely reassemble trigger housing.

#### Note

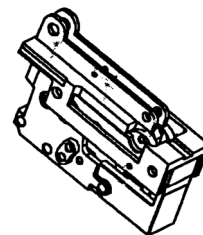
Series 14 triggers are slightly different in appearance from the current Series 18 triggers. Your sear may not necessarily look exactly like the one depicted. Simply cut the striker Sear away from corner to corner and polish the surface.

### Step 3

Place your adapter over the trigger housing. Line up the rear of the adapter to the indent at the rear of the housing. See figures 8 and ,9. The trigger is shown as it will fit on your action if the muzzle of the rifle is pointing to the left. Some older trigger housings already have a small hole drilled through at the back. Your adapter holes should line up with these holes. You will still have to drill and tap.

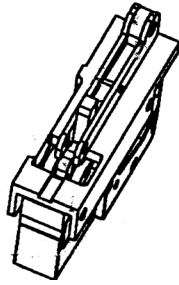


**Figure 8: Housing and Adapter**



**Figure 9: Housing and Adapter Assembled**

The adapter will fit snug on the trigger housing allowing the adapter to remain positioned in the correct place. Holes to be drilled in the trigger housing can be spotted using the adapter. Although the adapter has four holes in it, only two will be used, the rear left and front right. Use the short screw at the rear and the long crew at the front. If drilling and tapping through an assembled trigger exercise caution and avoid damaging components. Once you have drilled and tapped clean the trigger thoroughly. Assemble the adapter by placing the sear transfer bar into it and retaining it in place with the one-sixteenth roll pin. The pin also prevents the sear from interfering with the insertion of the bolt when the rifle is fully assembled. See figure 10.



**Figure 10: Adapter & sear Transfer Bar**

## Step 4

Fully assemble the trigger housing and adapter and fit the adapter to your Winchester action.

When fitting the adapter over the trigger housing make sure that the return spring on the Anschutz striker sear does not interfere with the adapter. Some have dual sided springs, which may touch the housing and not allow it to reset. Simply file a small notch with a needle file to give clearance.

From the top, your adapter looks similar to a regular Winchester trigger. Use the same orientation to fit the adapter. Align the adapter, sear transfer bar and action then drive

through the short, large diameter action pin. Fit this pin first. As there may be small differences in the action-hole spacing tolerance, the longer, smaller action pin might not immediately pass through. Keep the adapter and action pressed together. Clean out the hole using a one-eighth drill. Do this by hand using a drill chuck or small handvise. Drive through the long pin and make sure you assemble the bolt stop correctly. When driving the pins through the action and adapter be sure not to bend the sides of the adapter inwards. If this happens, your transfer bar will not move freely. Always check that your transfer moves freely.

Once assembled, cock the bolt and test your trigger. It is advisable to test it before fitting it into your stock. When the trigger fires cock the bolt again and the trigger should reconnect. If it fails to reconnect this means, you may have to remove a little more material on the top of your Anschutz sear

## Note

The Safety on the bolt may or may not work. Safeties come fitted in the factory according to the engagement of the sear and striker. Test the safety by cocking the bolt, engaging the safety and pulling the trigger. When disengaging the safety the striker may follow through. **Do this test safely pointing the rifle, unloaded, in a safe direction.** The stock will need to be further inlet. A competent gunsmith should do the work. Briley Mfg. can also do the installation for you.

All liability is the sole responsibility of the installer.